

BAND SAW

MODEL B25

The B25 features a four wheel carriage base. This saw is ideal for small to medium applications. Easy to disassemble for quick cleaning and maintenance.

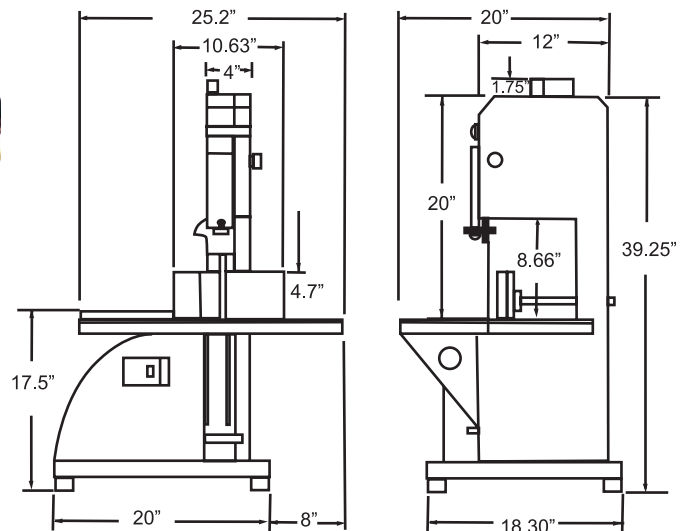

SPECIFICATIONS

Model	B25
Blade Length	78"
Cutting Capacity (H*W)	7.75" x 7.5"
HP	1 HP
Electrical	110V/60/1

Weight	248 lbs.
Shipping Weight	290 lbs..
Shipping Dimensions	26" x 32" x 46"
Item #	10270



OMCAN INC.
Food Machinery of America Inc.

Email: sales@omcan.com ♦ Phone: 1.800.465.0234 or 905.828.0234 ♦ Fax: 905.607.0234